



High pressure flat fan nozzles

Series 602 / 608 / 652



Sharp uniform flat fan with an extremely narrow jet depth.

Applications:
High pressure cleaners, steam jet cleaners

Materials:

Nozzle body: stainless steel
1.4305/303 SS

Insert: hardened stainless steel
1.4034 S

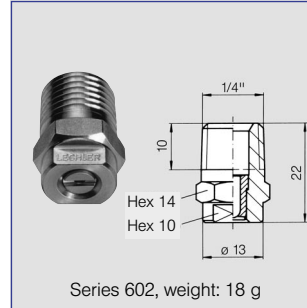
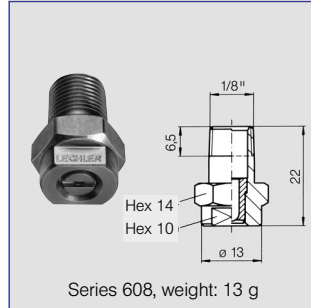

| [US gal/min.] at 40 psi | Nozzle-Code | | | Flow rate code | | | | A Ø [mm] | Ḃ [l/min] (Tolerance ± 2%) | | | | | | |
|-------------------------------|-------------|------|-----|----------------|------|------|------|----------------|----------------------------|-------|-------|-------|-------|-------|-------|
| | Connection | | | Spray angle | | | | | p [bar] | | | | | | |
| | 1/8" | 1/4" | nut | ↘15° | ↘30° | ↘45° | ↘60° | | 40 | 60 | 80 | 100 | 120 | 150 | 200 |
| 02 | 608 | 602 | 652 | 361 | 362 | 363 | 364 | 1,00 | 2,86 | 3,50 | 4,04 | 4,52 | 4,95 | 5,53 | 6,39 |
| 025 | 608 | 602 | 652 | 381 | 382 | 383 | 384 | 1,10 | 3,54 | 4,33 | 5,00 | 5,59 | 6,12 | 6,85 | 7,91 |
| 03 | 608 | 602 | 652 | 401 | 402 | 403 | 404 | 1,18 | 4,31 | 5,28 | 6,10 | 6,82 | 7,47 | 8,35 | 9,64 |
| 034 | 608 | 602 | 652 | 411 | 412 | 413 | 414 | 1,30 | 4,95 | 6,06 | 7,00 | 7,83 | 8,57 | 9,59 | 11,07 |
| 04 | 608 | 602 | 652 | 451 | 452 | 453 | 454 | 1,35 | 5,80 | 7,10 | 8,20 | 9,17 | 10,04 | 11,23 | 12,97 |
| 045 | 608 | 602 | 652 | 471 | 472 | 473 | 474 | 1,40 | 6,51 | 7,97 | 9,20 | 10,29 | 11,27 | 12,60 | 14,55 |
| 05 | 608 | 602 | 652 | 481 | 482 | 483 | 484 | 1,55 | 7,29 | 8,92 | 10,30 | 11,52 | 12,62 | 14,11 | 16,29 |
| 055 | 608 | 602 | 652 | 501 | 502 | 503 | 504 | 1,60 | 7,96 | 9,74 | 11,25 | 12,58 | 13,78 | 15,41 | 17,79 |
| 06 | 608 | 602 | 652 | 521 | 522 | 523 | 524 | 1,72 | 8,70 | 10,66 | 12,31 | 13,76 | 15,07 | 16,85 | 19,46 |
| 065 | 608 | 602 | 652 | 531 | 532 | 533 | 534 | 1,75 | 9,38 | 11,49 | 13,26 | 14,83 | 16,25 | 18,16 | 20,97 |
| 07 | 608 | 602 | 652 | 541 | 542 | 543 | 544 | 1,80 | 10,06 | 12,32 | 14,22 | 15,90 | 17,42 | 19,47 | 22,49 |
| 075 | 608 | 602 | 652 | 551 | 552 | 553 | 554 | 1,90 | 10,75 | 13,16 | 15,20 | 16,99 | 18,62 | 20,81 | 24,04 |
| 08 | 608 | 602 | 652 | 571 | 572 | 573 | 574 | 2,05 | 11,48 | 14,06 | 16,23 | 18,15 | 19,88 | 22,23 | 25,67 |
| 09 | 608 | 602 | 652 | 591 | 592 | 593 | 594 | 2,10 | 13,01 | 15,93 | 18,40 | 20,57 | 22,53 | 25,19 | 29,09 |
| 10 | 608 | 602 | 652 | 601 | 602 | 603 | 604 | 2,30 | 14,43 | 17,76 | 20,40 | 22,81 | 24,99 | 27,94 | 32,26 |
| 125 | - | 602 | 652 | 641 | 642 | 643 | 644 | 2,50 | 17,82 | 21,82 | 25,20 | 28,17 | 30,86 | 34,51 | 39,85 |
| 15 | - | 602 | 652 | 671 | 672 | 673 | 674 | 2,70 | 21,35 | 26,15 | 30,20 | 33,76 | 36,98 | 41,35 | 47,74 |
| 175 | - | 602 | 652 | 701 | 702 | 703 | 704 | 3,00 | 25,03 | 30,66 | 35,40 | 39,58 | 43,36 | 48,47 | 55,97 |
| 20 | - | 602 | 652 | 721 | - | 723 | 724 | 3,05 | 28,85 | 35,33 | 40,80 | 45,62 | 49,97 | 55,87 | 64,52 |
| 30 | - | 602 | 652 | - | - | 793 | - | 3,90 | 42,43 | 51,96 | 60,00 | 67,08 | 73,48 | 82,16 | 94,88 |

A = Equivalent bore diameter

| Connection Code | Connection | p _{max} [bar] |
|-----------------|------------|------------------------|
| A3.00 | BSPT | ca. 350 |
| A3.07 | NPT | ca. 350 |
| A3.29 | Lock nut | ca. 200 |

Example for ordering: Nozzle code + Flow rate code + Connection code = Ordering no.
602 + 361 + A3.07 = 602.361.A3.07
(Flat fan; 15°; 4,52 l/min. at 100 bar; 1/4" NPT)

Conversion formula for the above series: $\dot{V}_2 = \dot{V}_1 \cdot \sqrt{\frac{p_2}{p_1}}$

