

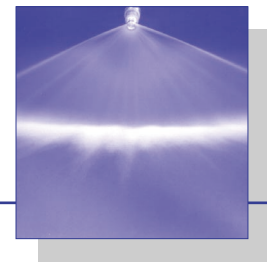

Tongue-type nozzles

Series 686



Wide flat fan with a sharply delimited jet pattern. Particularly clog-proof.

Applications:

Foam control in storage tanks and sewage treatment plants, cleaning and washing process, requiring powerful and concentrated water jets.

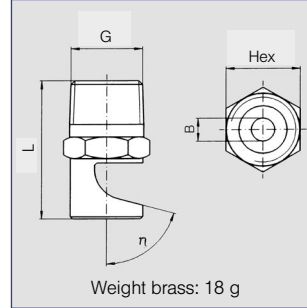

Spray angle	η	Ordering no.							B ∅ [mm]	ṽ [l/min]			Dimensions								Spray width B at p = 2 bar H = 250 mm		
		Type	Material-no.			Code				p [bar]			L [mm]				Hex [mm]						
			16 1.4305/303 SS	30 Brass	5E PVDF	1/8 BSPT	1/4 BSPT	3/8 BSPT		1/2 BSPT	1,0	2,0	5,0	R1/8	R1/4	R3/8	R1/2	R1/8	R1/4	R3/8		R1/2	
90°	50°	686. 406	-	○	-	CA	-	-	-	1,00	0,71	1,00	1,58	23	-	-	-	11	-	-	-	525	
	40°	686. 886	○	-	-	-	CC	-	-	4,20	11,31	16,00	25,30	-	36	-	-	-	17	-	-	530	
	40°	686. 926	○	-	-	-	-	CE	-	4,70	14,14	20,00	31,62	-	-	39	-	-	-	17	-	530	
140°	75°	686. 368	○	○	-	CA	-	-	-	0,80	0,45	0,63	1,00	23	-	-	-	11	-	-	-	1360	
		686. 408	○	○	-	CA	-	-	-	1,00	0,71	1,00	1,58	23	-	-	-	11	-	-	-	1370	
		686. 448	○	○	-	-	CC	-	-	-	1,20	0,88	1,25	1,98	-	28	-	-	-	14	-	-	1370
		686. 488	○	○	-	CA	CC	-	-	-	1,30	1,13	1,60	2,53	23	28	-	-	11	14	-	-	1370
		686. 528	○	○	-	CA	CC	-	-	-	1,50	1,41	2,00	3,16	23	28	-	-	11	14	-	-	1370
		686. 568	○	○	○	CA	-	-	-	-	1,70	1,77	2,50	3,59	23	-	-	-	11	-	-	-	1370
		686. 608	○	○	-	CA	CC	-	-	-	1,90	2,23	3,15	4,98	23	28	-	-	11	14	-	-	1370
		686. 648	○	○	-	-	CC	-	-	-	2,20	2,83	4,00	6,32	-	28	-	-	-	14	-	-	1370
		686. 688	○	○	-	CA	CC	-	-	-	2,40	3,54	5,00	7,91	23	28	-	-	11	14	-	-	1370
		686. 768	○	○	-	-	CC	-	-	-	3,00	5,66	8,00	12,65	-	28	-	-	-	14	-	-	1370
		686. 808	○	○	-	CA	CC	-	-	-	3,40	7,07	10,00	15,81	23	28	-	-	11	14	-	-	1370
		686. 828	○	○	-	-	CC	-	-	-	3,60	7,92	11,20	17,71	-	28	-	-	-	14	-	-	1370
		686. 848	○	○	-	-	CC	-	-	-	3,80	8,80	12,50	19,76	-	28	-	-	-	14	-	-	1370
		686. 868	○	○	-	-	CC	-	-	-	4,00	9,90	14,00	22,14	-	28	-	-	-	14	-	-	1370
		686. 888	○	○	-	-	CC	-	-	-	4,20	11,31	16,00	25,30	-	28	-	-	-	14	-	-	1370
		686. 908	○	○	-	-	CC	-	-	-	4,50	12,73	18,00	28,46	-	28	-	-	-	14	-	-	1370
686. 928	○	-	-	-	-	CE	-	-	4,70	14,14	20,00	31,62	-	-	32	-	-	-	17	-	1370		
686. 968	-	○	-	-	-	CE	CG	-	5,30	17,68	25,00	39,53	-	-	32	40	-	-	17	22	1370		
686. 988	○	-	-	-	-	CE	CG	-	5,60	19,80	28,00	44,27	-	-	32	40	-	-	17	22	1370		

B = bore diameter

Can also be used for air or saturated steam (see page 6.7)

The folded page at the end of the catalogue will give you a survey on the various assembly possibilities. For complete assembly accessories, please refer to „Accessories“.

Example: Type + Material no. + Code = Ordering no.
for ordering 686. 406 + 30 + CA = 686. 406. 30. CA

Conversion formula for the above series: $\dot{V}_2 = \dot{V}_1 \cdot \sqrt{\frac{p_2}{p_1}}$