



# Tongue-type nozzles

## Series 688 / 689



**Hard, sharp flat fan, narrowly delimited jet pattern. Not prone to clogging.**

Applications:

Cleaning, washing, degreasing and phosphating, preparation techniques.

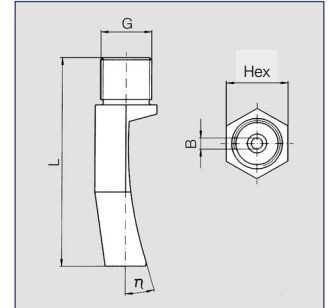

| Spray angle | η   | Ordering no. |                     |    |      |    |         | B<br>∅<br>[mm] | ṽ [l/min] |       |           |             | Dimensions |                  | Weight<br>(1.4305) | Spray width<br>B<br>at p = 2 bar |  |
|-------------|-----|--------------|---------------------|----|------|----|---------|----------------|-----------|-------|-----------|-------------|------------|------------------|--------------------|----------------------------------|--|
|             |     | Type         | Material-no         |    | Code |    | p [bar] |                |           |       | L<br>[mm] | Hex<br>[mm] | H          |                  |                    |                                  |  |
|             |     |              | 16<br>1.4305/303 SS | 5E | CE   | 90 | 0,5     |                | 1,0       | 2,0   |           |             | 5,0        | H =<br>250<br>mm |                    | H =<br>500<br>mm                 |  |
| 45°         | 35° | 688. 763     | ○                   | -  | CE   | -  | 3,0     | 4,00           | 5,66      | 8,00  | 12,65     | 43          | 19         | 114 g            | 220                | 440                              |  |
|             | 30° | 688. 843     | ○                   | -  | CE   | -  | 3,8     | 6,25           | 8,84      | 12,50 | 19,76     | 50          | 19         | 133 g            | 220                | 440                              |  |
|             | 29° | 688. 923     | ○                   | -  | CE   | -  | 4,8     | 10,00          | 14,14     | 20,00 | 31,62     | 59          | 22         | 247 g            | 220                | 440                              |  |
|             | 25° | 689. 003     | ○                   | ○  | -    | 90 | 6,0     | 15,75          | 22,27     | 31,50 | 49,81     | 65/74       | 24/27      | 470 g            | 250                | 490                              |  |

B = Bore diameter

|                      |                 |          |                     |          |                     |
|----------------------|-----------------|----------|---------------------|----------|---------------------|
| <b>Example</b>       | <b>Type</b>     | <b>+</b> | <b>Material no.</b> | <b>=</b> | <b>Ordering no.</b> |
| <b>for ordering:</b> | <b>688. 763</b> | <b>+</b> | <b>16</b>           | <b>=</b> | <b>688. 763. 16</b> |

The folded page at the end of the catalogue will give you a survey on the various assembly possibilities. For complete assembly accessories, please refer to „Accessories“.



Phosphating line